

DN775

**OPERATORS
MANUAL**

KLARK-TEKNIK

Kidderminster Worcestershire England
Telephone (0562) 741515 Telex 339821

3. INTRODUCTION

The DN773 Stereo Broadcast Digital Audio Delay Line is a compact 1U 19 inch rack mounting unit, ideal for use in a variety of broadcast applications, recording studios and disc cutting suites, and in any other application where precise delay is required.

The DN773 Digital Delay uses the latest digital and analogue technology to achieve its superior performance. In house research and development by Klark-Teknik engineers, ensured that special emphasis was placed on the design of very high quality A/D and D/A converters.

The use of 16 bit Successive Approximation A/D converter and 16 bit D/A converter, ensures optimum performance in the DN773 and other Klark-Teknik professional digital audio products.

The input and output filters used, are the proprietary Low Pass Hybrid KTR009 types, especially designed to achieve the optimum distortion, noise performance, and to ensure very high reliability.

The DN773 has a maximum delay of 10.48 seconds stereo, or 20.97 seconds mono, this delay can be internally adjusted to a resolution of 20 microseconds, providing accurate tamper proof system calibration.

***N.B.** The operating instructions should be read carefully before using the unit.

27th October 1988

DN775

SETTING DELAY TIMES

<u>LINK</u>	<u>DELAY INCREMENT</u>
A	DO NOT USE
B	16.2uS
C	32.4uS
D	64.8uS
E	129.6uS
F	259.2uS
G	518.4uS
H	1.0368mS
I	2.0736mS
J	4.1472mS
K	8.2944mS
L	16.5888mS
M	33.1776mS
N	66.3552mS
O	132.7104mS
P	265.4208mS
Q	530.8416mS
R	1.0616832 secs
S	2.1233664 secs
T	4.2467328 secs

ST2 = 33 Mode
ST3 = 45 Mode

4. INSTRUMENT FAMILIARISATION

4.1 FRONT PANEL FUNCTIONS

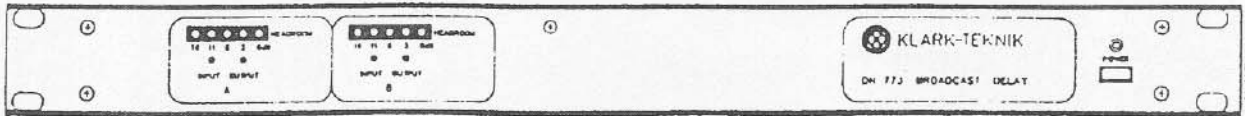

Fig. 4-1: Front Panel

(1) POWER ON/OFF SWITCH

Before switching on, check that the unit has been set for the mains voltage being used. This is indicated on the rear panel.

(2) INPUT LEVEL CONTROLS

Should be set so that with the normal signal, the 3dB LED on the headroom indicator, illuminates during the loud passages.

(3) HEADROOM INDICATOR

Indicates the headroom left in the digital section before clipping commences. The top L.E.D. (0dB), activates at 2dB below the clipping point.

*N.B. For maximum signal to noise performance, the 3dB L.E.D. should light up during loud passages.

(4) OUTPUT LEVEL CONTROL

Output level is set at +8dBu for maximum level i.e. the onset of the 0dB LED on the headroom indicator. This can be adjusted with the output level controls. Range of adjustment is from zero to +18dBu for maximum level.

Note: The 0dB L.E.D. illuminates at approximately 2dB below the clipping point.

*0dBu = 0.775V R.M.S.

4.2 REAR PANEL FUNCTION

(1) OPERATING VOLTAGE

This is clearly marked on an adhesive label. See "Installation Section" for voltage change-over instructions.

(2) MAINS POWER SOCKET

This is a standard IEC 3 pin socket.

(3) MAINS FUSE

(4) SERIAL NUMBER

The serial number on this label should be quoted in any correspondence concerning the unit.

(5) EARTH LIFT SWITCH

Connects or disconnects XLR Pin 1 (signal screen) from the chassis (mains ground), for use in case of ground loops.

*NOTE: FOR SAFETY REASONS DO NOT REMOVE THE EARTH FROM THE MAINS POWER CABLE.

(6) AUDIO CONNECTORS

These are complimentary 3 pin XLR style sockets. See "Installation Section" for wiring details.

4.3 OPERATING CONSIDERATIONS

4.3.1 AUDIO SIGNAL LEVELS

Due to the inherent limitation of digital audio products, it is important that special care be placed on setting the operating levels, to achieve the best possible performance.

This can best be achieved by the following:-

- i) Turn down to minimum, the output level control.
- ii) Inject peak operating signal and turn up the input level as high as practical (0dB L.E.D. = 2dB below internal clipping of the unit).
- iii) Adjust the output level control as required.

4.3.2 ERRORS IN DELAY TIMES

Although the DN773 is capable of very accurate delays to a resolution of 20 microseconds, a fixed delay of approximately 110 microseconds must be added to the calculated delay, this fixed delay is caused by the sampling process and necessary filter networks, it varies slightly with frequency.

4.3.3 DELAYED TURN ON

The DN773 incorporates delayed turn on circuitry which prevents spurious information being read out when the unit is switched on. Upon power up, the unit remains in the bypass mode for the equivalent of the delay time setting.

5. INSTALLATION .

5.1 MOUNTING

The DN773 is designed for standard 19 inch rack mounting and is 44mm (1.75 inch) high and 300mm (11.75 inch) deep, excluding connectors.

Observe the following when mounting:-

- a) Use a well ventilated rack.
- b) Do not mount on top of heat producing equipment (i.e. power amplifiers etc).
- c) Use fan assisted ventilation if rack exceeds 40 C.

5.2 POWER REQUIREMENTS

The factory set nominal operating voltage is clearly indicated on the rear panel. Power connection is made via the standard 3 pin IEC Power Cable provided. The chassis to mains earth connection made by this cable, must not be removed. Maximum power consumption of this unit is 20 VA. For power cables using flying leads, the wires in the cable are colour coded as follows:-

BROWN:	LIVE
BLUE:	NEUTRAL
GREEN/YELLOW:	EARTH

6. AUDIO INPUT AND OUTPUT CONNECTORS

The audio connectors are 3 pin XLR type, wired to the standard shown below.

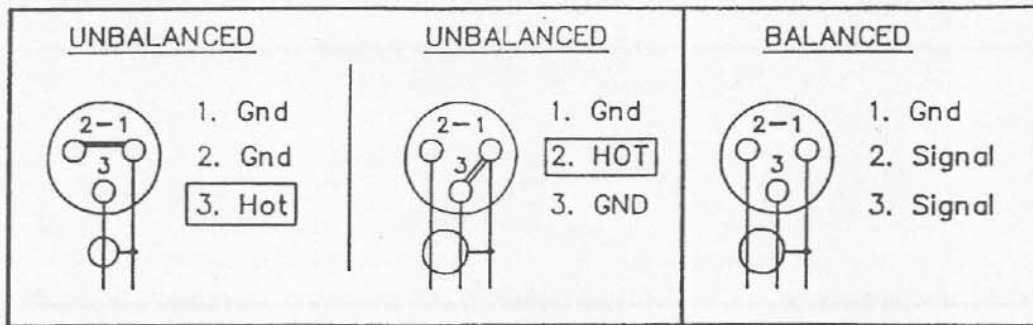

Fig. 6-0: Audio Connections

6.1 INPUTS

The standard inputs use a differential electronically balanced circuit, which is both voltage and current balanced, and achieves a symmetry of better than -50dB from 20-10KHZ.

If used with an unbalanced line, wire as shown in diagram. Either Pin 2 or Pin 3 can be used as signal.

6.2 OUTPUTS

The standard outputs are transformer balanced as standard output XLR connections:-

Pin 1	Circuit Ground
Pin 2	Signal
Pin 3	Signal

If unbalanced output line is to be used, wire as in unbalanced diagram (fig. 6-0).

7. SETTING DELAY TIMES

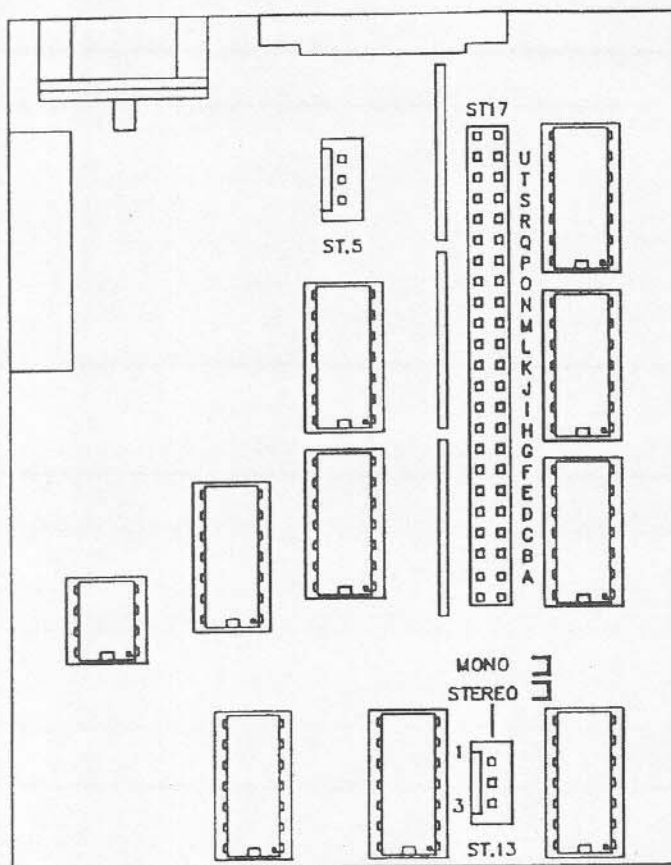

Fig. 7.1A

STEREO MODE----- MONO MODE

10.48576 Secs -U-	20.97152 Secs
5.24288 Secs -T-	10.48576 Secs
2.62144 Secs -S-	5.24288 Secs
1.31072 Secs -R-	2.62144 Secs
655.36 mS -Q-	1.31072 Secs
327.68 mS -P-	655.36 mS
163.84 mS -O-	327.68 mS
81.92 mS -N-	163.84 mS
40.96 mS -M-	81.92 mS
20.48 mS -L-	40.96 mS
10.24 mS -K-	20.48 mS
5.12 mS -J-	10.24 mS
2.56 mS -I-	5.12 mS
1.28 mS -H-	2.56 mS
640 uS -G-	1.28 mS
320 uS -F-	640 uS
160 uS -E-	320 uS
80 uS -D-	160 uS
40 uS -C-	80 uS
20 uS -B-	40 uS
Do not use -A-	20 uS

Fig. 7.1B

The connector strip used for setting delays is located inside the unit. When a link is inserted, the delay is increased by the amount in the above table (fig. 7.1B). The process for changing delays is as follows:-

- 1) Switch off the unit and remove the power cable.
- 2) Remove top dust cover, so as to expose ST17.
- 3) Insert or remove links to the required delay length (The maximum settable delay will be dependant on the amount of memory installed).
- 4) Replace dust cover.

7.1 SELECTING STEREO OR MONO

The stereo or mono selector ST13 (see fig. 7.1A), is located inside the DN773, and can be accessed in the same manner as the delay settings. For stereo operation the link must join pins 2 and 3, for mono operation pins 1 and 2. When in mono mode use channel B only and for optimum performance IC13 should be removed.

8. SAFETY CONSIDERATIONS

- a) For safety and interference reasons, the supply earth connection should always be used.
- b) The audio signal ground (pin 1 XLR's), may be isolated from the chassis ground by means of the "earth lift" switch, located on the rear panel. The shells of the XLR's are always connected to the chassis earth.
- c) Do not rely on the front panel mounting, as a means of chassis earthing.
- d) Although the DN773 has been designed for a minimum RFI interference, it is not advisable to mount the unit near radio sensitive equipment (i.e. radio microphone receivers).
- e) For the best possible performance in sensitive areas, it is advisable that the units have transformer balanced inputs and outputs.
- f) Make sure that the unit's voltage setting is in the correct range, incorrect setting can cause intermittent operation or excessive heating of the unit.

9. SERVICE .

If normal operating conditions are adhered to, the DN773 will not require any periodic maintenance other than, cosmetic removal of dust from the front panel using a dry, soft cloth. Due to the complexity of the circuitry used in the DN773, it is essential that all servicing is carried out by an authorized **KLARK-TEKNIK** service centre.

NOTE: Attempted repairs by a non-authorized service centre, will invalidate the warranty.

9.1 RETURNING A UNIT FOR SERVICE

Before returning a unit for repair or modification, first contact the factory or service centre to ensure that the problem necessitates this action.

* Units returned for service should include full description of the problem, the senders full details, including telephone number and the preferred method of re-shipment.

Returned equipment must be shipped pre-paid, fully insured and packed in the original packaging.

KLARK-TEKNIK assumes no responsibility for shipment of the product, from the customer to the factory or service centre.

10. SPECIFICATIONS

INPUTS	Two electronically balanced (transformer balancing to order) via XLR connector.
LEVELS	0dBu to +22dBu
IMPEDANCE	20K Balanced 10K Unbalanced
OUTPUTS	Two transformer balanced as standard.
LEVEL	+8dBm nominal for maximum level, adjustable from zero to +18dBm via the output level controls on the front panel.
IMPEDANCE	<50ohms to drive loads of 600ohms and above.
FREQUENCY RESPONSE	20Hz - 20kHz +/- 1dB (Both channels at any level, at all delay settings).
T.H.D.	Less than 0.01% @ 1kHz Less than 0.03% @ 20Hz to 20kHz (Distortion plus noise at any delay setting).
DYNAMIC RANGE	(At any delay setting) 20Hz - 20kHz unweighted, better than 90dB.
DELAY RANGE	Zero to 10.48 seconds stereo Zero to 20.97 seconds mono (dependent on memory size)

11. LIMITED WARRANTY

Klark-Teknik does not assume to make any warranty, or assume any liability which is not strictly in accordance with the following.

This product is manufactured by Klark-Teknik, and is warranted to be free from defects in components and factory workmanship, under normal use and service, for a period of one year from the date of delivery to the purchaser or his agent.

Klark-Teknik guarantees to repair, or at its option, replace the product at no charge to its owner, should the product fail to perform as specified, provided the unit is returned, shipping pre-paid to the factory or authorized service centre.

The warranty shall not be applicable and be deemed void should this product be subjected to any of the following:-

- * 1. Repair work or alteration, by persons other than those authorized by Klark-Teknik in such a manner as to injure, in the sole judgement of Klark-Teknik, the performance, stability, reliability or safety of this product.
- * 2. Misuse, negligence, accident, act of god, war or civil insurrection.
- * 3. Connection, installation, adjustment or use otherwise than in accordance with the instructions provided by Klark-Teknik.

Klark-Teknik shall not be responsible for loss or damage, either direct or from consequence, caused by failure or the inability of this product to perform as specified.

Klark-Teknik reserves the right to refuse acceptance of product returned this warranty, without its prior consent. Returned equipment must be shipped pre-paid, fully insured, and packed in Klark-Teknik's approved packaging. No responsibility for loss or damage of product during shipment, to or from its factory or authorized service centre, shall be taken by Klark-Teknik.

Klark-Teknik reserves the right to make alterations or improvements in the design or engineering of its products, without obligation to make such changes to the purchaser's unit.

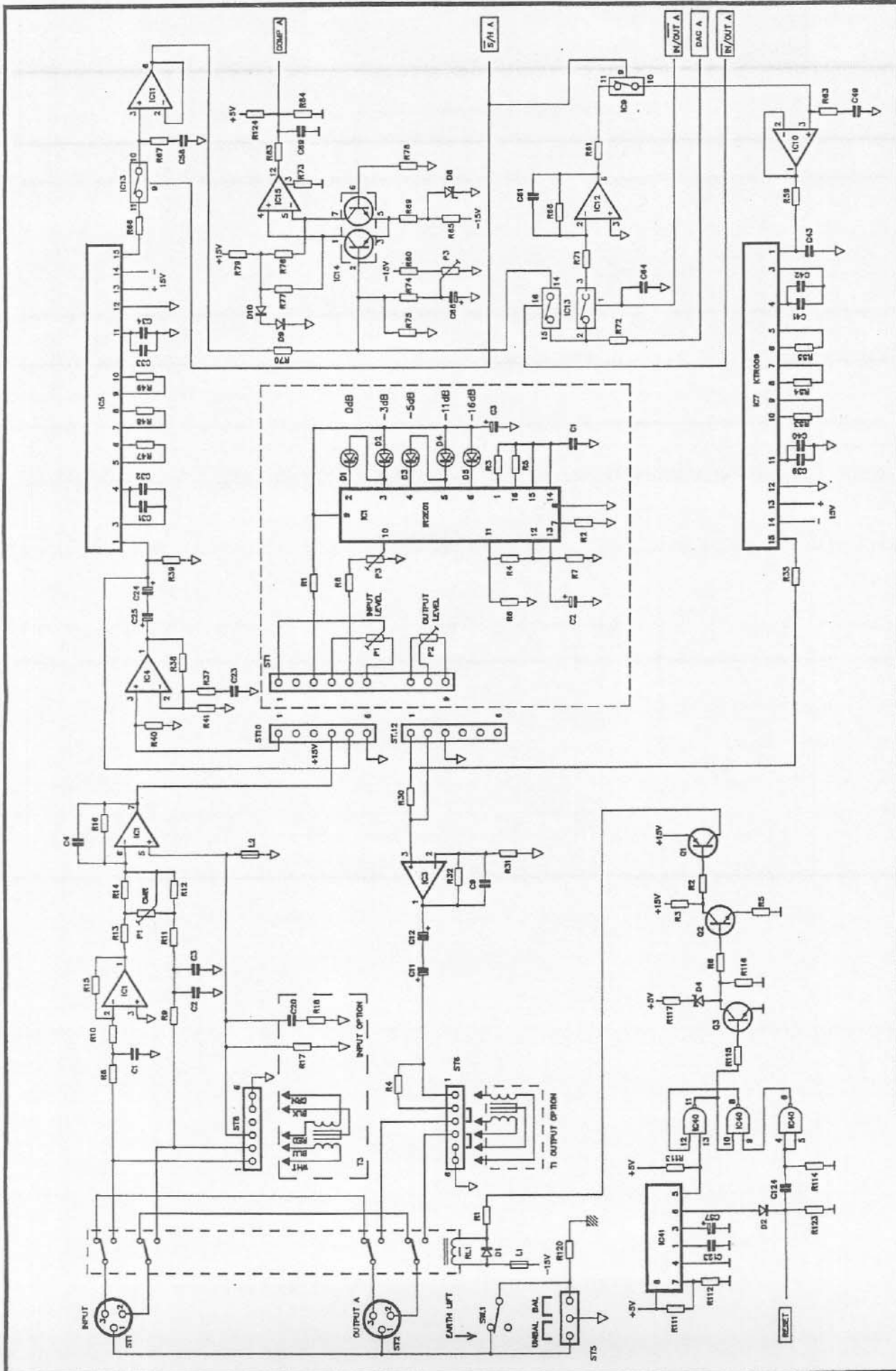

DN773 ANALOGUE SECTION CHANNEL A(sheet 1) BRD: 2653+2654 09.FEB.87

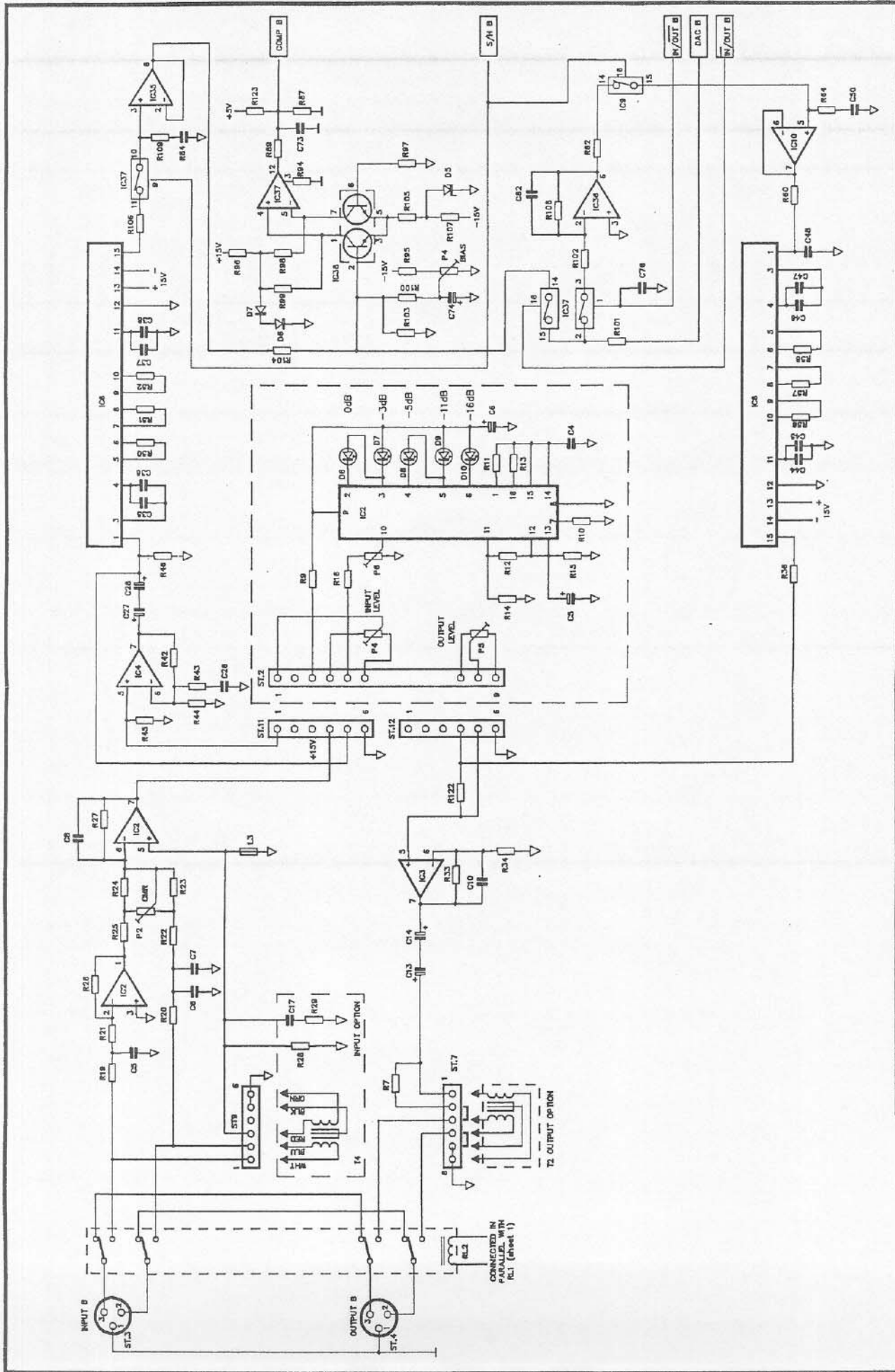

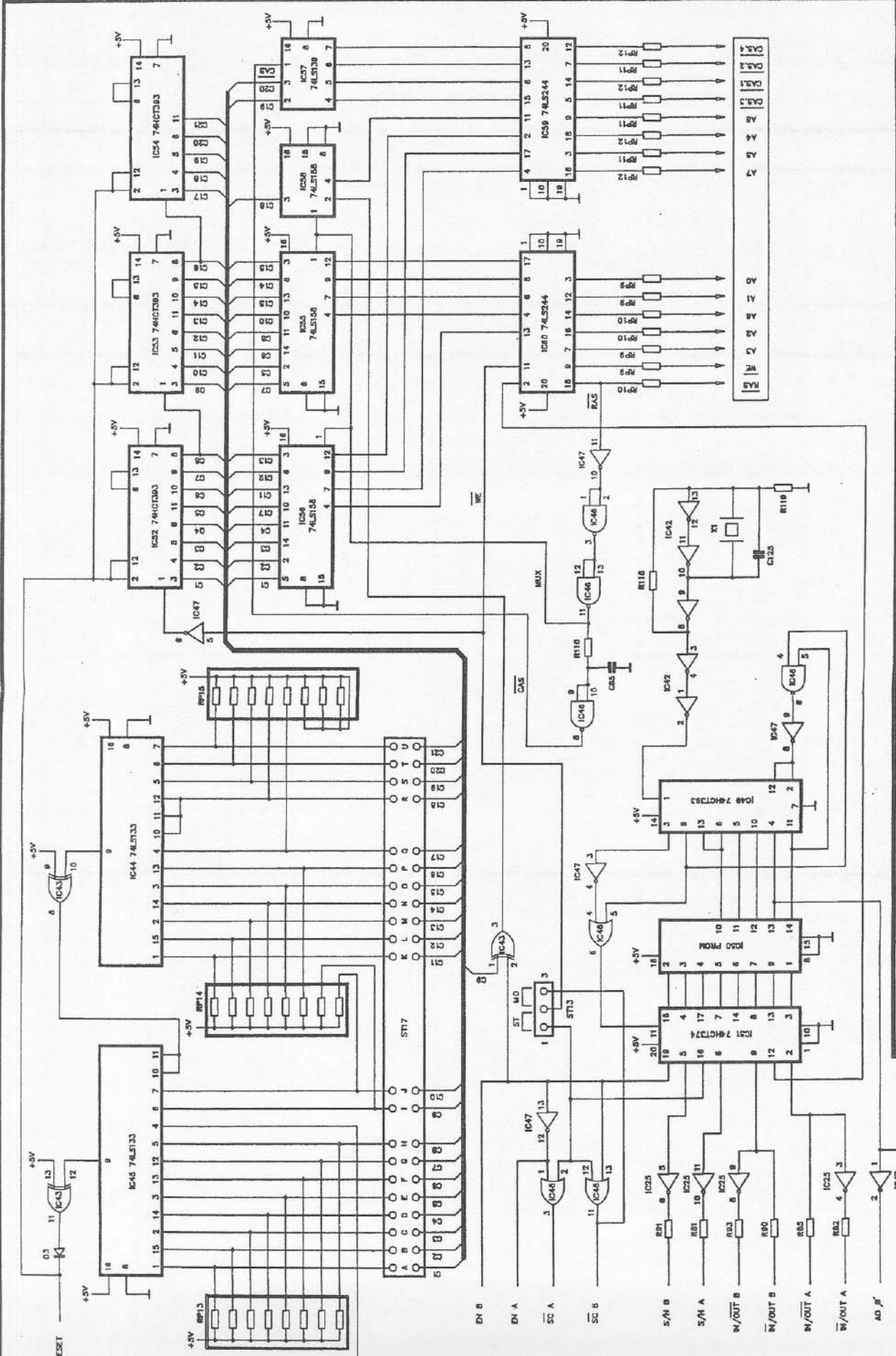

DN773 ADDRESS COUNTER BUS SECTION(sheet 3) BRD:2653 03.MAR.87

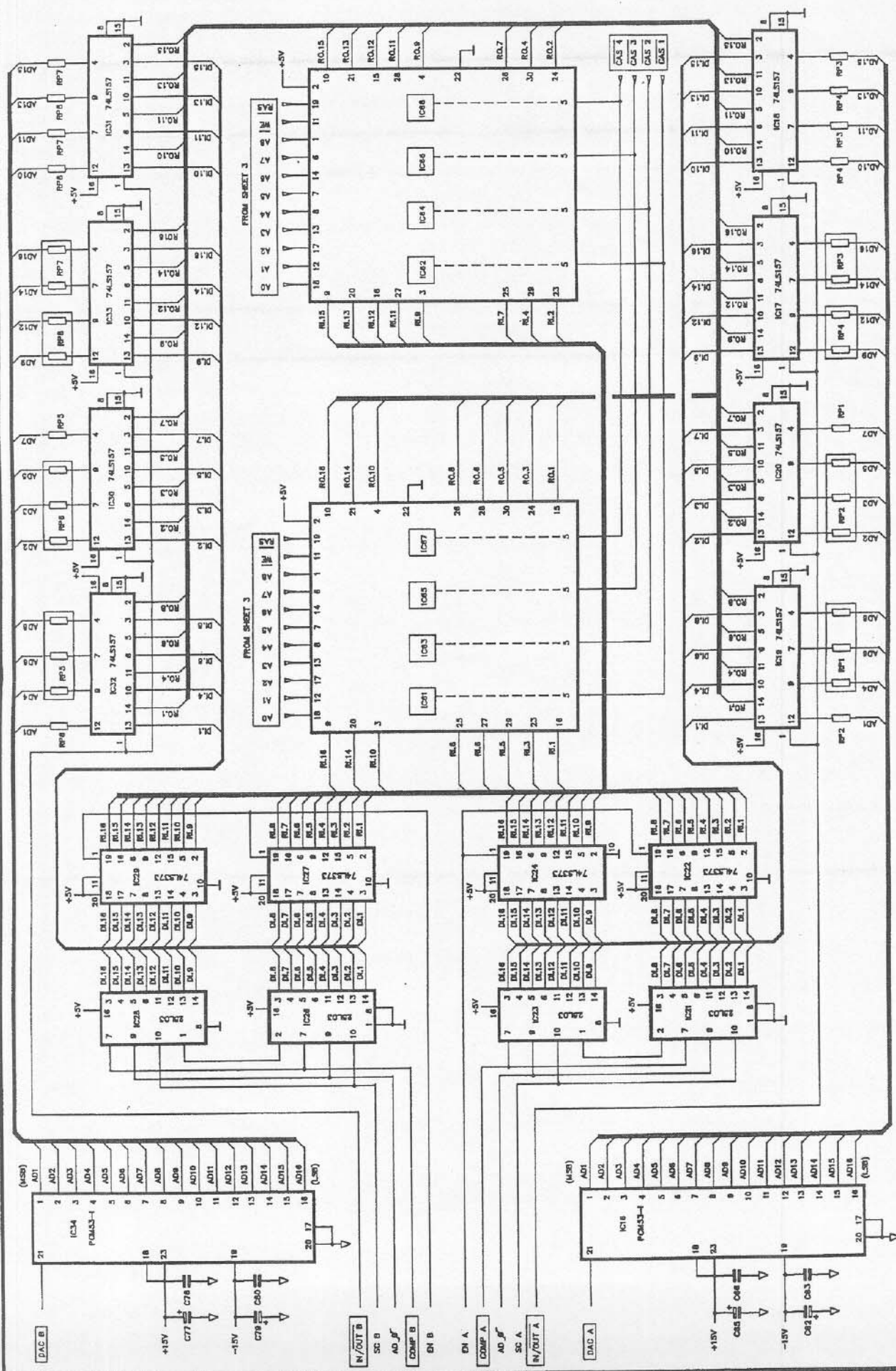

DN773 DIGITAL SECTION(sheet 4) BRD:2653 04.MAR.87